

● Procédés manuels, semi-automatiques ou entièrement automatisés, robotisés :

- bouterollage,
- brasage cuivre, étain, argent, inox,
- clinchage,
- clipsage,
- collage,
- rivetage,
- roulage,
- sertissage,
- soudage MIG, TIG, SFI, Micro Plasma, laser, par résistance,
- vissage.

● Lignes d'assemblage spécifiques.

● Quantités :

- prototypes, petites, moyennes et grandes séries.

● Finitions :

- traitements thermiques : trempe, recuit...
- traitements de surface : anodisation, alodine, argenture, dorure, étamage, nickelage, zingage, téflonnage, peintures époxy ...

● Manual, semi-automated or fully automated processes:

- snapping,
- copper and silver solder, tin and stainless steel brazing,
- clinching,
- clipping,
- gluing,
- riveting,
- rolling,
- crimping,
- MIG, TIG, SFI, Micro Plasma, laser or resistance welding,
- screwing.

● Special purpose assembly lines.

● Quantity:

- prototypes, small, medium and high series.

● Finishing:

- heat treatments: hardening, annealing...
- surface treatments: anodizing, silver plating, gold plating, tin plating, nickel plating, zinc plating, PTFE finish, Epoxy paint...



montage/assembly

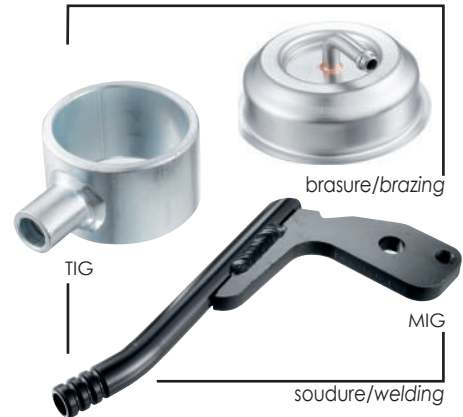

brasure/brazing

soudure/welding



soudure par résistance/resistance welding



sertissage/crimping

l'interlocuteur de choix

P.A.E. de Pré-Mairy - 125, allée de Primavera Park - PRINGY - 74370 ANNECY - France

Tél : +33 (0) 4 50 66 87 45

info@intermecca.com - www.intermecca.com